

2700 SERIES DOOR SELECTION CHART

MODEL NUMBER	APPROXIMATE DOOR WEIGHT	FRAME MATERIAL	EXTERIOR SKINS BOTH SIDES	DOOR THICKNESS	INSULATING VALUE	
					FIBERGLASS	URETHANE
2702	6 LB/SQ FT	2" X 1" X 16 GA.	18/16 GA.	2 1/8"	R=7.7 U=.13	R=14.3 U=.07
2724	10.5 LB/SQ FT	2" X 4" X 14 GA.	16/14 GA.	2 1/8"	R=7.7 U=.13	R=14.3 U=.07
2742	10.5 LB/SQ FT	4" X 2" X 14 GA.	16/14 GA.	4 1/8"	R=15.4 U=.07	R=28.6 U=.04

DOOR SPECIFICATIONS

- DOORS WILL BE CONSTRUCTED OF A TUBULAR STEEL PERIMETER FRAME. ALL CORNER JOINTS SHALL BE MITERED, REINFORCED, WELDED, AND THE SURFACE WELDS GROUND SMOOTH. ALL INTERMEDIATE STEEL STIFFENERS ARE WELDED TO THE FRAME ON APPROXIMATELY 24", 36", OR 48" CENTERS. 18, 16, OR 14 GAUGE COLD ROLLED STEEL SKINS WILL BE WELDED TO THE FRAME. ALL EXPOSED WELDS WILL BE GROUND SMOOTH.
- OPTIONS:
 - GAVANNEALED STEEL SKINS
 - NON-FLAMMABLE FIBERGLASS INSULATION
 - RIGID URETHANE INSULATION
- DOORS WILL BE REINFORCED TO RECEIVE HARDWARE.
- HARDWARE FOR THE DOORS WILL HAVE A GALVANIZED OR ZINC PLATED FINISH. HARDWARE SHALL INCLUDE BOX TRACK, TRACK BRACKETS WITH ADJUSTABLE WALL ANGLES, STAY ROLLERS, END STOPS, AND WALL BOLTS. HANGERS SHALL BE ZINC PLATED.
- ALL EXPOSED DOOR SURFACES WILL RECEIVE ONE COAT OF GRAY EPOXY RUST-INHIBITING PRIME PAINT AT THE FACTORY. ANY FINISH PAINT IS BY OTHERS.

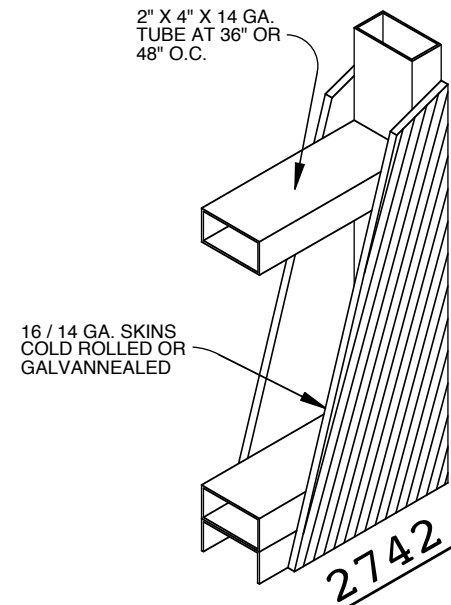
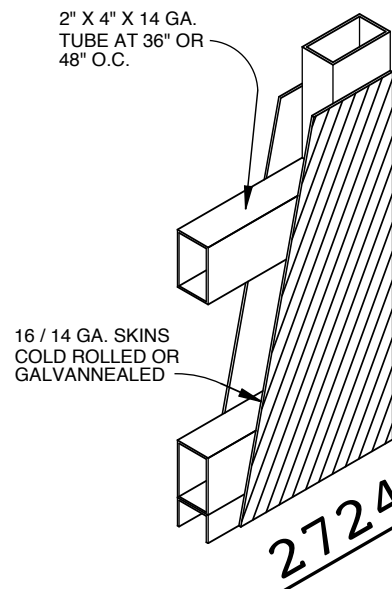
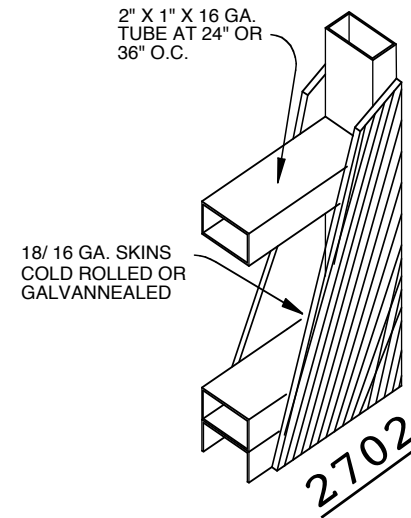

TYPICAL DOOR SECTIONS

NOTE: OTHER FRAME MATERIALS MAY BE AVAILABLE TO MEET OPENING SIZE AND/OR WINDLOAD REQUIREMENTS

2700 SERIES SLIDING DOOR



PROJECT		JOB NUMBER:	
LOCATION	ARCHITECT	DATE:	
CONTRACTOR	DRAWN BY:		
DISTRIBUTOR	DRAWING NO.		OF